



Fabco TC-180 Transfer case Parts Manual

Pro Gear and Transmission presents Fabco TC-180 transfer case parts manual to assist in identifying the parts for your Fabco unit.

If you need any assistance identifying the correct transfer case unit for your truck and equipment, contact your Fabco replacement part specialists at Pro Gear and Transmission.

Pro Gear stocks every part for your Fabco transfer case including: transfer case housings, shafts, gaskets, caps, brackets, plugs, shims and much more.

Pro Gear Transmission has same day shipping and 1000's of products in stock and ready to ship internationally for your next project.

For parts or service contact the Fabco specialists at Pro Gear & Transmission, Inc.

1 (877) 776-4600
(407) 872-1901
parts@progear.com

[Check Inventory](#)

[Email Us](#)

[Call Us](#)



TC-180
TRANSFER CASE
PARTS MANUAL

PARTS MANUAL

TABLE OF CONTENTS

Fig. 1.....	2
Fig. 2.....	3
Fig. 3.....	4
TC-180 Upper Shaft Assembly w/o PTO.....	5-6
TC-180 Upper Shaft Assembly with PTO	7-8
TC-180 Upper Shaft Assembly with Hydraulic Pump Output.....	9-10
TC-180 Intermediate Shaft Assembly.....	11-12
TC-180 Front Output Shaft Assembly.....	13-14
TC-180 Rear Output Shaft Assembly without Neutral.....	15-16
TC-180 Rear Output Shaft Assembly with Neutral.....	17-18
TC-180 Single Acting Air Shift Cylinder Assembly.....	19-20
TC-180 Lubrication Hoses and Fittings w/o PTO.....	21-22
TC-180 Lubrication Hoses and Fittings with PTO.....	23-24
TC-180 Remaining Parts.....	25-26

TO USE THIS PARTS MANUAL

1. Refer to the exploded view which illustrates the needed part.
2. Find the required part in the exploded view and then note the item number.
3. Locate the item number in the parts list for part number, description and quantity.

NOTE: When ordering parts, specify model number, part number, serial number or other information that is on the Fabco nameplate located on the transfer case housing.

Contact Fabco if your configuration does not match parts in this manual.

Part numbers contained in this manual were in effect at the time the manual was approved for printing and are subject to change without notice or liability. Fabco Division reserves the right to change parts at any time.

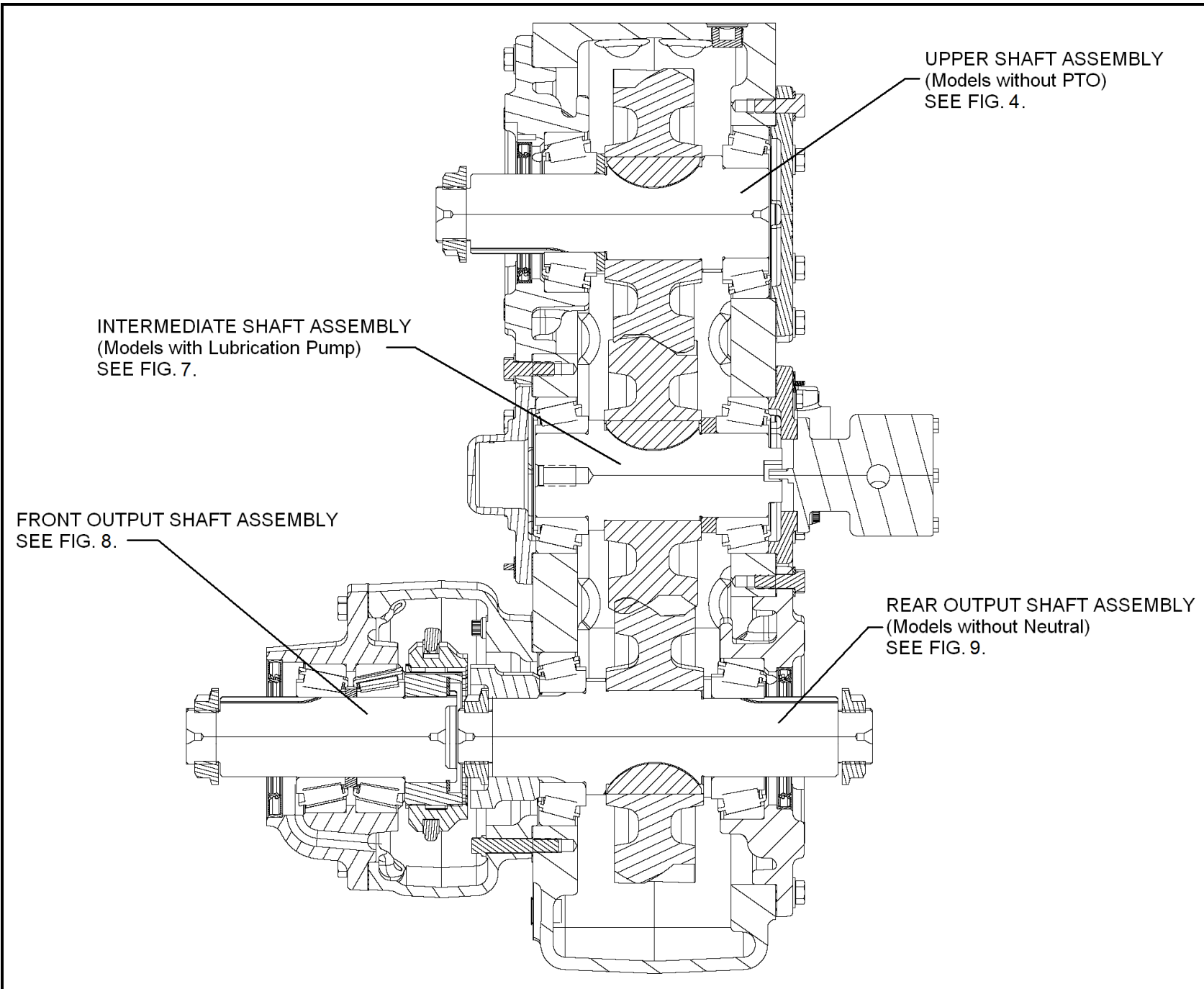
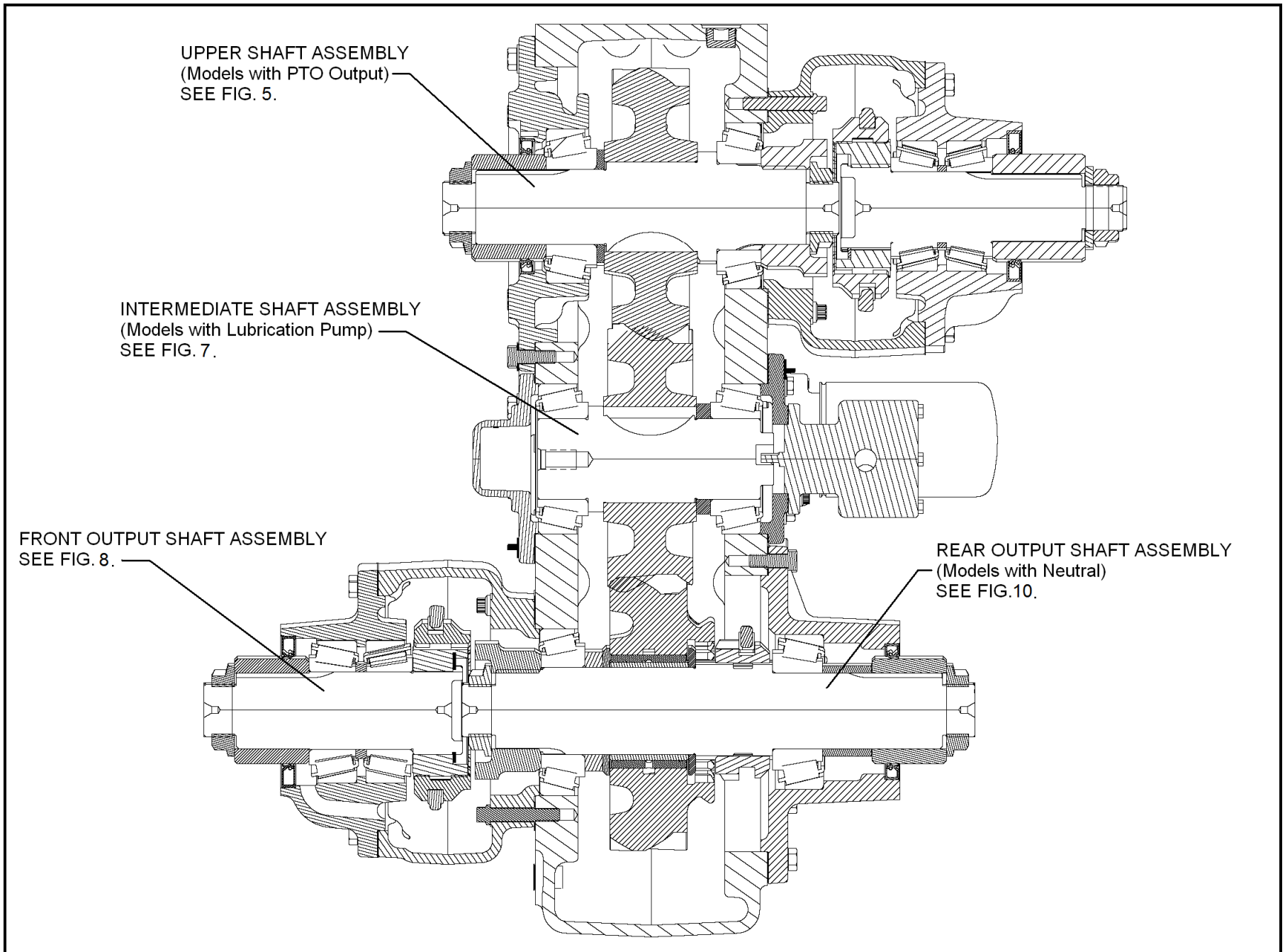

FIG. 1 - TYPICAL TC-180 BASIC TRANSFER CASE

Pro Gear and Transmission, Inc. | 906 West Gore St, Orlando, FL 32805
+1 (877) 776-4600 | +1 (407) 872-1901
www.progearandtransmission.com | www.pgtruckparts.com | parts@eprogear.com



**FIG. 2 - TYPICAL TC-180 BASIC TRANSFER CASE
(SHOWN WITH NEUTRAL AND PTO)**

Pro Gear and Transmission, Inc. | 906 West Gore St, Orlando, FL 32805
 +1 (877) 776-4600 | +1 (407) 872-1901
www.progearandtransmission.com | www.pgtruckparts.com | parts@eprogear.com

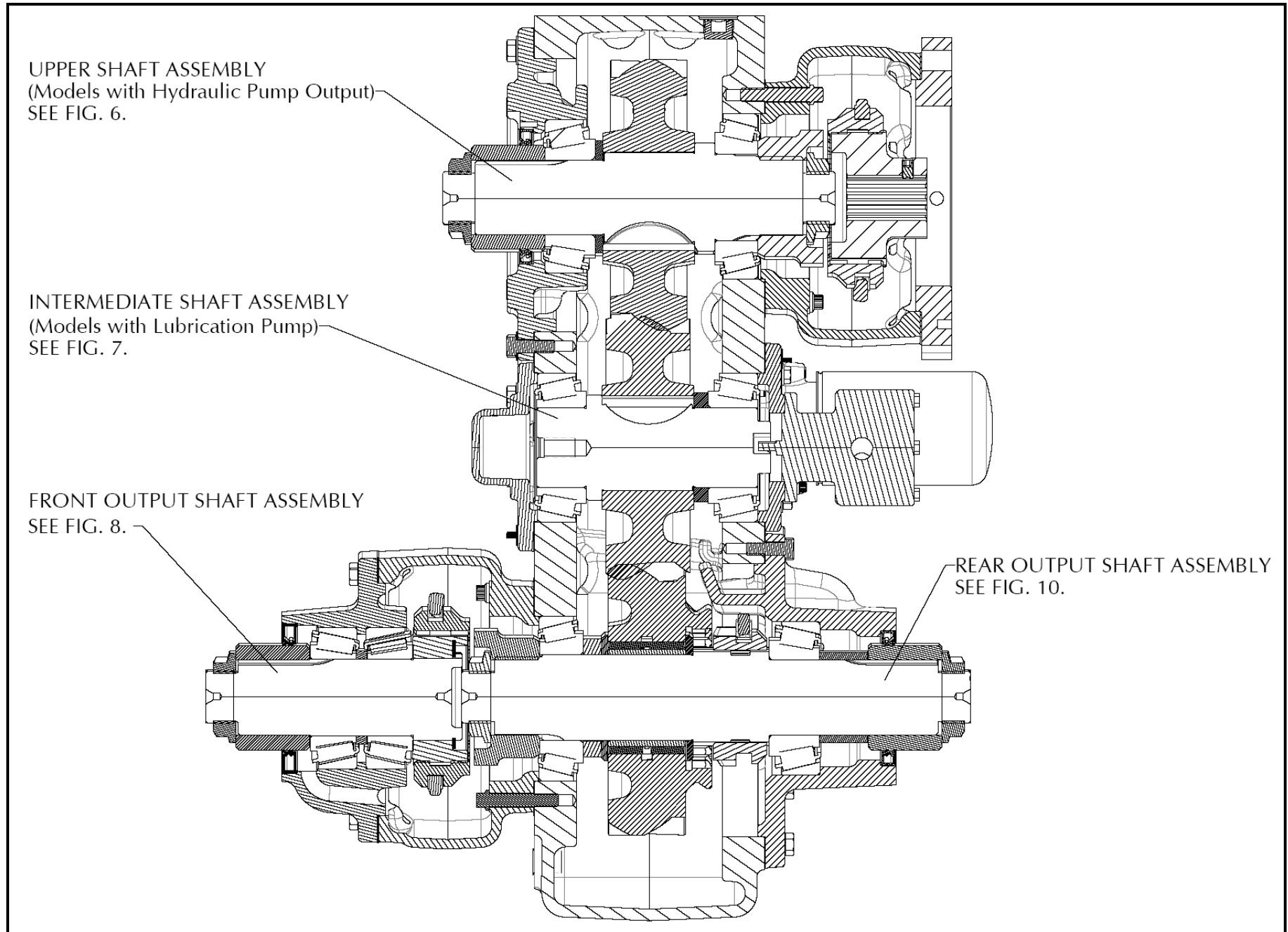

**FIG. 3 - TYPICAL TC-180 BASIC TRANSFER CASE
(SHOWN WITH NEUTRAL AND HYDRAULIC PUMP PAD)**

Pro Gear and Transmission, Inc. | 906 West Gore St, Orlando, FL 32805
+1 (877) 776-4600 | +1 (407) 872-1901
www.progearandtransmission.com | www.pgtruckparts.com | parts@eprogear.com

TC-180 Upper Shaft Assembly
Models without PTO Output.
See Fig. 4

<u>ITEM</u>	<u>PART NO.</u>	<u>DESCRIPTION</u>	<u>QTY.</u>	<u>FOOT</u> <u>NOTE</u>
1	233-0375	BEARING CUP	1	
6	233-0489	BEARING CONE	1	
7	233-0492	BEARING CUP	1	
8	233-0493	BEARING CONE	1	
18	235-0729-002	CAP, FINISHED, TOP RER W/LUBE 1	1	
25	237-0542-003	CARRIER	1	
29	265-0238	BOLT, 7/16-14 x 1-1/4 GR5 HH	16	
36A	273-0687	BRACKET, LIFTING	2	
43	427-0523	GASKET, CARRIER	1	
46	427-0567	GASKET, HOUSING DECLUTCH	1	
48	432-0779	GEAR, 33 TOOTH, UPPER OR LOWER	1	
64	688-0738	NUT LOCK HEX 1 3/4-12	1	
69	732-0467	SEAL, OIL	1	
77	744-0376-001	*SHIM, BRG, DECLUTCH, (180) .002 THK	A/R	1
77	744-0376-002	*SHIM, BRG, DECLUTCH, (180) .005 THK	A/R	1
77	744-0376-003	*SHIM, BRG, DECLUTCH, (180) .0015 THK	A/R	1
77	744-0376-004	*SHIM, BRG, DECLUTCH, (180) .030 THK	A/R	1
92	776-0229	SHAFT	1	
113	927-0347	WASHER, 7/16 SAE PLAIN	16	
118	927-0797	WASHER, UPPER SHAFT	1	
123	966-0326	KEY, WOODRUFF, HARDENED	1	
124	724-0755	SCREW, #10 X 1/2 SELF TAPPING, HEX HEAD	3	
125	927-0864-002	WASHER	3	

Footnotes:

1. See service manual.
2. Select one spacer ring. See service manual.

**TC-180 Upper Shaft Assembly
Models with PTO Output.
See Fig. 5**

ITEM	PART NO.	DESCRIPTION	QTY.	FOOT		ITEM	PART NO.	DESCRIPTION	QTY.	FOOT	
					NOTE						NOTE
1	233-0375	BEARING CUP	1			85A	756-0233-3	*RING, BEARING SPACER .306 THICK			2
6	233-0489	BEARING CONE	1			85B	756-0233-4	*RING, BEARING SPACER .311 THK			2
7	233-0492	BEARING CUP	1			85C	756-0233-5	*RING, BEARING SPACER .316 THK			2
8	233-0493	BEARING CONE	1			85D	756-0233-6	*RING, BEARING SPACER .321 THK			2
13	233-0523	BEARING CUP & CONE ASSEMBLY	2			85E	756-0233-7	*RING, BEARING SPACER .326 THK			2
23	237-0393	CARRIER, BEARING & SEAL	1			85F	756-0233-8	*RING, BEARING SPACER, .331 THK.			2
25	237-0542-003	CARRIER	1			85G	756-0233-9	*RING, BEARING SPACER, .336 THK.			2
29	265-0238	BOLT, 7/16-14 x 1-1/4 GR5 HH	18			91	762-0288	RING, SNAP	1		
43	427-0523	GASKET, CARRIER	1			94	776-0233	SHAFT	1		
45	432-0426	GEAR, CLUTCH COLLAR.	1			98	776-0237	SHAFT, FD & PTO	1		
47	432-0563	GEAR, CLUTCH	1			111	883-0992	TUBE, METAL, SHIPPING.	1		
48	432-0779	GEAR, 33 TOOTH, UPPER OR LOWER	1			113	927-0347	WASHER, 7/16 SAE PLAIN	10		
52	432-0634	GEAR, CLUTCH, FRONT DRIVE & PTO	2			117	927-0775-005	WASHER, FLAT, HARDENED	1		
63	688-0694	NUT, 1-1/2-12 HEX SELF LOCKING	1			118	927-0797	WASHER, UPPER SHAFT	1		
64	688-0738	NUT LOCK HEX 1 3/4-12	2			123	966-0326	KEY, WOODRUFF, HARDENED	1		
68	732-0466	SEAL, OIL	1			124	724-0755	SCREW, #10 X 1/2 SELF TAPPING, HEX HEAD	3		
69	732-0467	SEAL, OIL	1			125	927-0864-002	WASHER	3		
77	744-0376-001	*SHIM, BRG, DECLUTCH, (180) .002 THK	A/R	1		126	427-0567	GASKET, HOUSING DECLUTCH	1		
77	744-0376-002	*SHIM, BRG, DECLUTCH, (180) .005 THK	A/R	1							
77	744-0376-003	*SHIM, BRG, DECLUTCH, (180) .015 THK	A/R	1							
77	744-0376-004	*SHIM, BRG, DECLUTCH, (180) .030 THK	A/R	1							

Footnotes:

1. See service manual.
2. Select one spacer ring. See service manual.

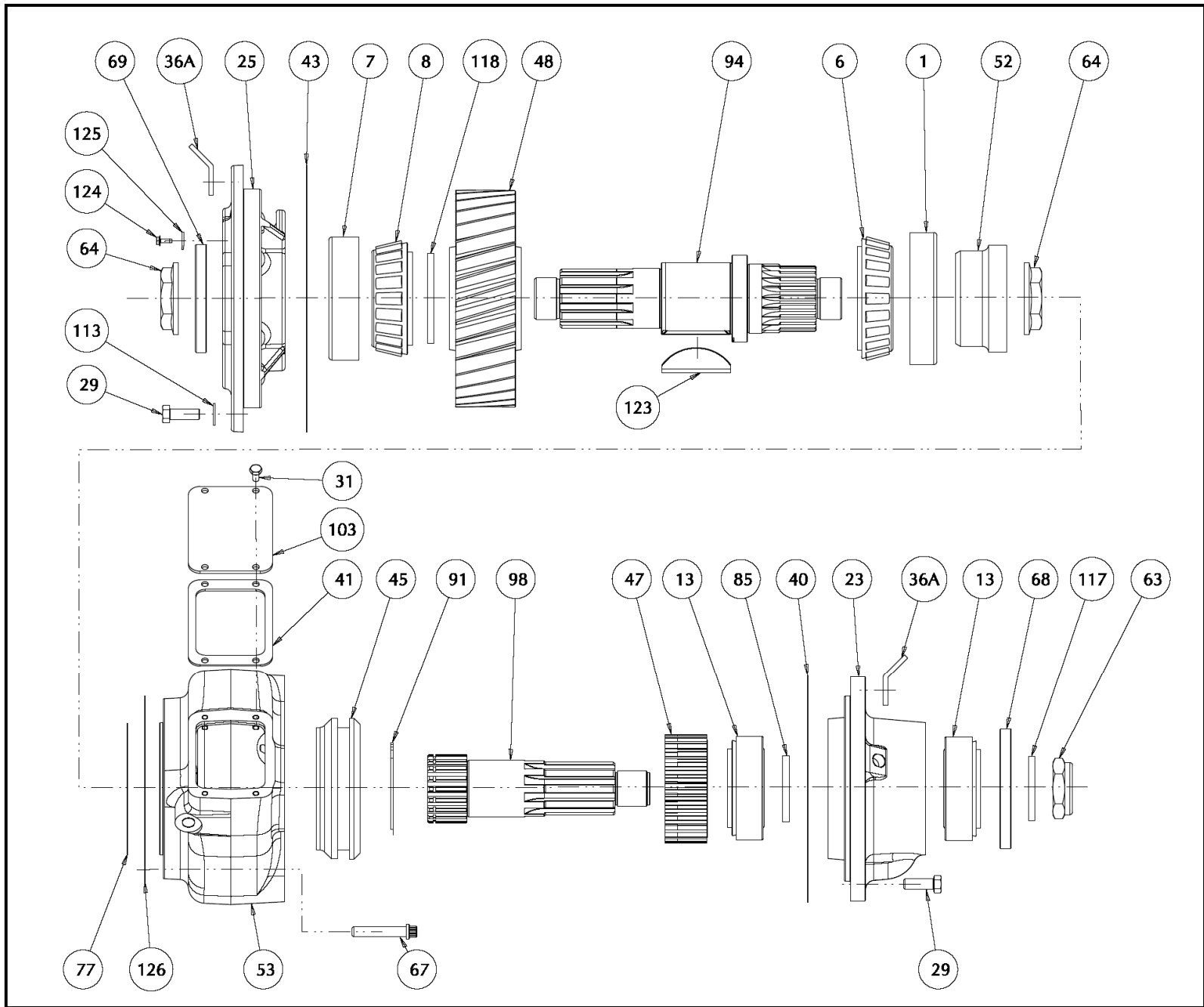

FIG. 5 - UPPER SHAFT ASSEMBLY

Models with PTO Output

Pro Gear and Transmission, Inc. | 906 West Gore St, Orlando, FL 32805

+1 (877) 776-4600 | +1 (407) 872-1901

www.progearandtransmission.com | www.pgtruckparts.com | parts@eprogear.com

TC-180 Upper Shaft Assembly
Models with Hydraulic Pump Output.
See Fig. 6

ITEM	PART NO.	DESCRIPTION	FOOT		ITEM	PART NO.	DESCRIPTION	FOOT	
			QTY.	NOTE				QTY.	NOTE
1	233-0375	BEARING CUP	1		52	432-0634	GEAR, CLUTCH, FRONT DRIVE & PTO	2	
6	233-0489	BEARING CONE	1		53	478-0364	HOUSING, DECLUTCH, 6.75in BC (180)	1	
7	233-0492	BEARING CUP	1		64	688-0738	NUT LOCK HEX 1 3/4-12	2	
8	233-0493	BEARING CONE	1		67	724-0677	SCREW, CAP 7/16-14 x 2-1/4, 12PT FLANGED	6	
25	237-0542-003	CARRIER	1		69	732-0467	SEAL, OIL	1	
29	265-0238	BOLT, 7/16-14 x 1-1/4 GR5 HH	18		77	744-0376-001	*SHIM, BRG, DECLUTCH, (180) .002 THK	A/R	1
30	265-0239	BOLT, 7/16-14 x 1 GR5 HH	8	3	77	744-0376-002	*SHIM, BRG, DECLUTCH, (180) .005 THK	A/R	1
30	724-0268	SCREW, CAP 7/16-14 x 1 12PT FLANGED	8	4	77	744-0376-003	*SHIM, BRG, DECLUTCH, (180) .015 THK	A/R	1
31	265-0343	BOLT, 1/4-20 x 1/2 GR5 HH	4		77	744-0376-004	*SHIM, BRG, DECLUTCH, (180) .030 THK	A/R	1
40	427-0375	GASKET, DECLUTCH CARRIER	1		103A	793-0566	PLATE,DECLUTCH COVER w/1/4 NPT LUB PT.	1	
41	427-0376	GASKET, DECLUTCH COVER	1		104	792-0867	PLATE SAE C 4-BOLT HYD PUMP MTG.	1	3
43	427-0523	GASKET, CARRIER	1		104	793-0462	PLATE SAE D 2 OR 4 BOLT HYD PUMP MTG	1	4
45	432-0426	GEAR, CLUTCH COLLAR.	1		113	927-0347	WASHER, 7/16 SAE PLAIN	10	
46	432-0494	GEAR,PUMP DRIVE,14T,12/24P,1.25 ID	1	3	118	927-0797	WASHER, UPPER SHAFT	1	
46	432-0626	GEAR,PUMP DRIVE,13T,8/16P,1.75 ID	1	4	126	427-0567	GASKET, HOUSING DECLUTCH	1	
48	432-0779	GEAR, 33 TOOTH, UPPER OR LOWER	1		127	724-0244	SCREW, SET 3/8-16 x 5/8 HEX SOCKET	2	

Footnotes:

1. See service manual.
2. Select one spacer ring. See service manual.
3. For SAE "C" 4-Bolt Hydraulic Pump Mounting Pad with SAE "C" 1.25 Dia.-14 Splined Gear.
4. For SAE "D" 2 or 4-Bolt Hydraulic Pump Mounting Pad with SAE "D" 1.75 Dia.-13 Splined Gear.

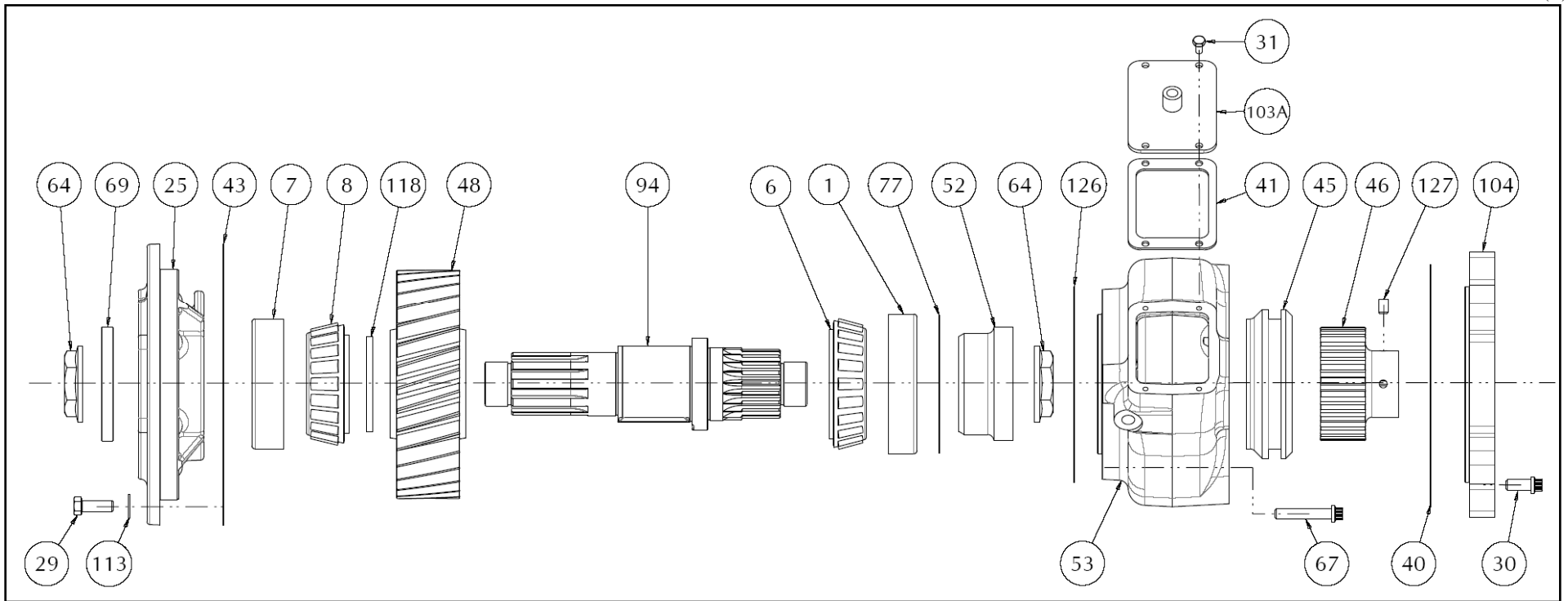

FIG. 6 - UPPER SHAFT ASSEMBLY
Models with Hydraulic Pump Output

TC-180 INTERMEDIATE SHAFT ASSEMBLY**See Fig. 7**

<u>ITEM</u>	<u>PART NO.</u>	<u>DESCRIPTION</u>	<u>QTY.</u>	<u>FOOT NOTE</u>
7	233-0492	BEARING CUP	2	
9	233-0494	BEARING CONE	2	
19	235-0572-001	CAP, INTERMEDIATE	1	
21	235-0687	CAP, INTERMEDIATE, TC-170-1.1 & 1.3	1	
29	265-0238	BOLT, 7/16-14 x 1-1/4 GR5 HH	12	
42	427-0468	GASKET, OIL PUMP	1	
44	427-0524	GASKET	1	
49	432-0792	GEAR, 33 TOOTH, INTERMEDIATE	1	
65	724-0233	SCREW, CAP 5/16-24 x 3/4in, 12PT FLANGED	4	
79	744-0356-001	*SHIM, RED .002 THK	A/R	1
79	744-0356-002	*SHIM, BLUE .005 THK	A/R	1
79	744-0356-003	*SHIM, PINK .015 THK	A/R	1
79	744-0356-004	*SHIM, CORAL .030 THK	A/R	1
93	776-0364	SHAFT, INTERMEDIATE	1	
102	786-0324	PUMP ASSEMBLY	1	
107	836-0223	VENT, BREATHER, 3/8 NPT.	1	
113	927-0347	WASHER, 7/16 SAE PLAIN	12	
119	927-0798	WASHER, INTERMEDIATE SHAFT	1	
123	966-0326	KEY, WOODRUFF, HARDENED	1	

Footnotes:

1. See service manual.
2. Select one spacer ring. See service manual.

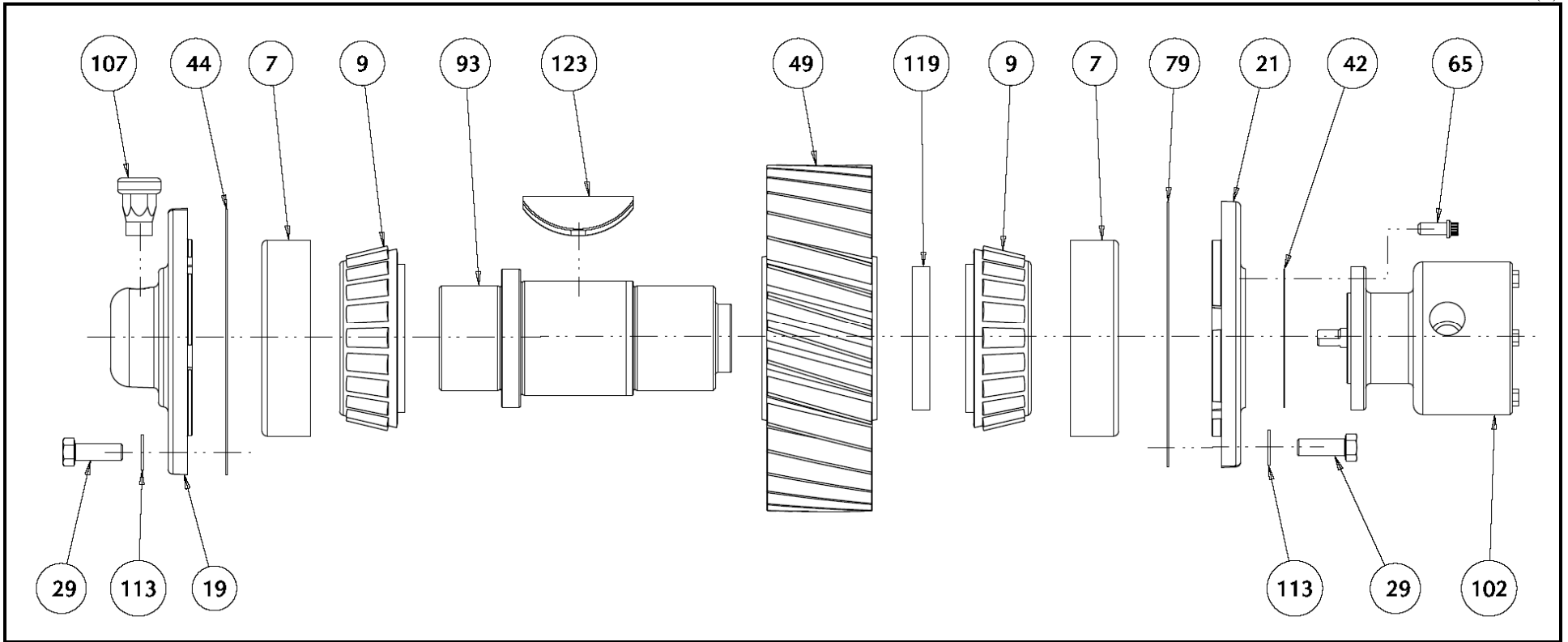

FIG. 7 - INTERMEDIATE SHAFT ASSEMBLY

TC-180 FRONT OUTPUT SHAFT ASSEMBLY**See Fig. 8**

<u>ITEM</u>	<u>PART NO.</u>	<u>DESCRIPTION</u>	<u>QTY.</u>	<u>FOOT NOTE</u>
2	233-0443	BEARING CONE	2	
3	233-0444	BEARING CUP	2	
22	237-0427-002	CARRIER	1	
29	265-0238	BOLT, 7/16-14 x 1-1/4 GR5 HH	8	
31	265-0343	BOLT, 1/4-20 x 1/2 GR5 HH	4	
45	432-0426	GEAR, CLUTCH COLLAR.	1	
40	427-0375	GASKET, DECLUTCH CARRIER	1	
41	427-0376	GASKET, DECLUTCH COVER	1	
46	427-0567	GASKET, HOUSING DECLUTCH	1	
47	432-0563	GEAR, CLUTCH	1	
53	478-0364	HOUSING, DECLUTCH, 6.75" BC (180)	1	
64	688-0738	NUT LOCK HEX 1 3/4-12	1	
67	724-0677	SCREW, CAP 7/16-14 x 2-1/4, 12PT FLANGED	6	
68	732-0466	SEAL, OIL	1	
71	736-0939	*RING, BEARING SPACER, .360 THK.		2
71A	736-0942	*RING, BEARING SPACER, .365 THK.		2
71B	736-0943	*RING, BEARING SPACER, .370 THK		2
71C	736-0944	*RING, BEARING SPACER, .375 THK.		2
71D	736-0959	*RING, BEARING SPACER, .380 THK		2
71E	736-0962	*RING, BEARING SPACER, .385 THK		2
77	744-0376-001	*SHIM, BRG, DECLUTCH, (180) .002 THK	A/R	1
77	744-0376-002	*SHIM, BRG, DECLUTCH, (180) .005 THK	A/R	1
77	744-0376-003	*SHIM, BRG, DECLUTCH, (180) .0015 THK	A/R	1
77	744-0376-004	*SHIM, BRG, DECLUTCH, (180) .030 THK	A/R	1
91	762-0288	RING, SNAP	1	
95	776-0234	SHAFT, FRONT OUTPUT.	1	
103	792-0866	PLATE, DECLUTCH COVER	1	

Footnotes:

1. See service manual.
2. Select one spacer ring. See service manual.

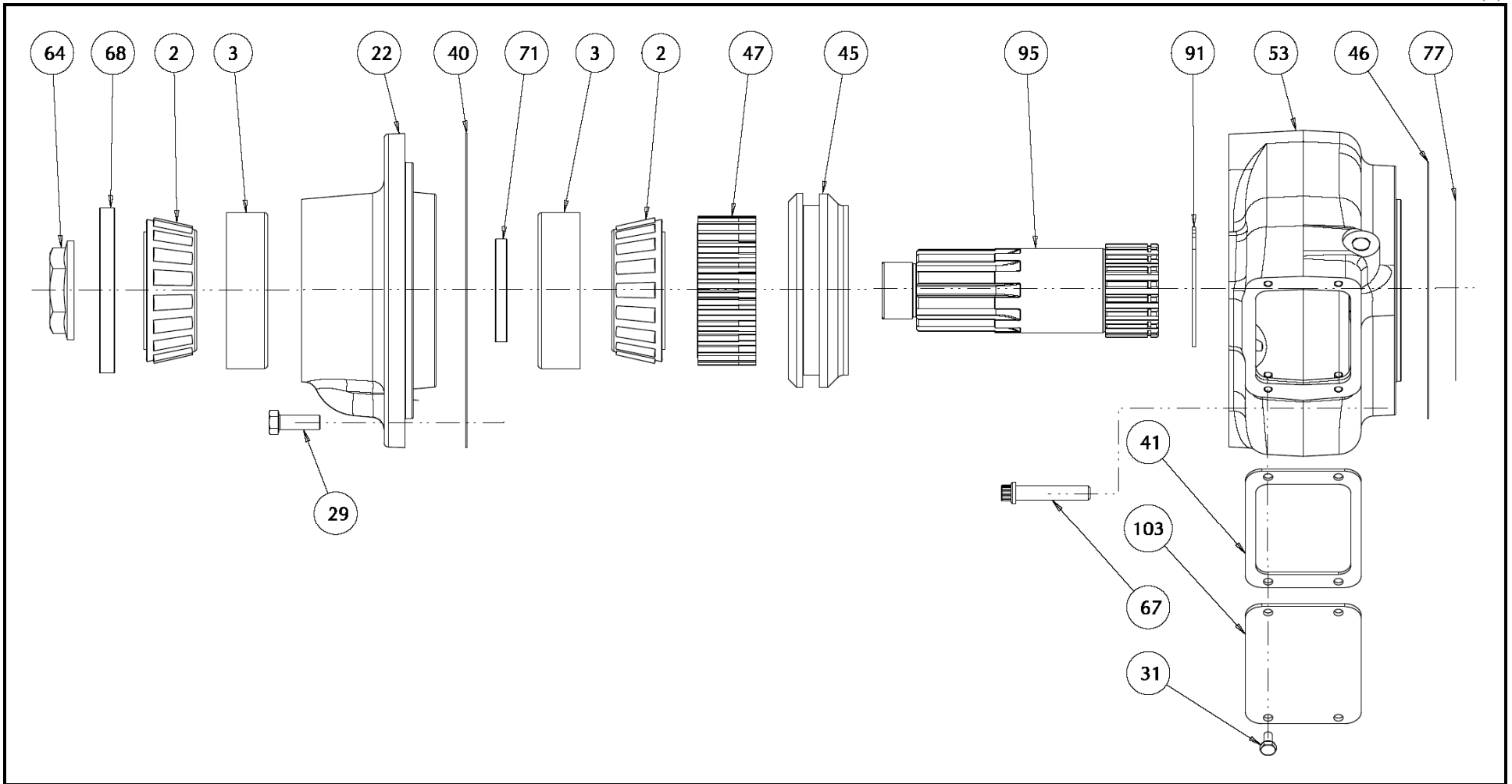

FIG. 8 - FRONT OUTPUT SHAFT ASSEMBLY

TC-180 REAR OUTPUT SHAFT ASSEMBLY**Models without Neutral****See Fig. 9**

<u>ITEM</u>	<u>PART NO.</u>	<u>DESCRIPTION</u>	<u>QTY.</u>	<u>FOOT NOTE</u>
1	233-0375	BEARING CUP	1	
6	233-0489	BEARING CONE	1	
7	233-0492	BEARING CUP	1	
8	233-0493	BEARING CONE	1	
24	237-0542-001	CARRIER	1	
29	265-0238	BOLT, 7/16-14 x 1-1/4 GR5 HH	10	
43	427-0523	GASKET, CARRIER	1	
48	432-0779	GEAR, 33 TOOTH, UPPER OR LOWER	1	
52	432-0634	GEAR, CLUTCH, FRONT DRIVE & PTO	1	
64	688-0738	NUT LOCK HEX 1 3/4-12	2	
69	732-0467	SEAL, OIL	1	
94	776-0233	SHAFT	1	
113	927-0347	WASHER, 7/16 SAE PLAIN	10	
118	927-0797	WASHER, UPPER SHAFT	1	
123	966-0326	KEY, WOODRUFF, HARDENED	1	

Footnotes:

1. See service manual.
2. Select one spacer ring. See service manual.

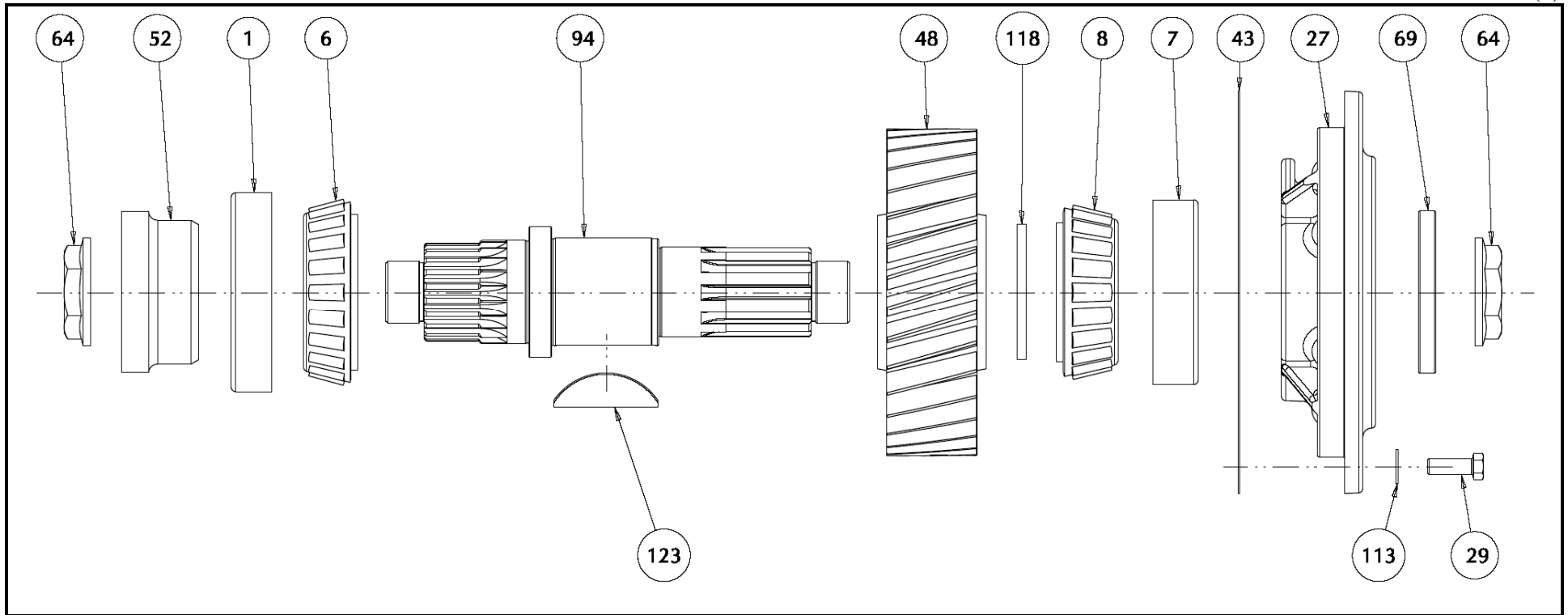

FIG. 9 - REAR OUTPUT SHAFT ASSEMBLY
Models without Neutral

TC-180 REAR OUTPUT SHAFT ASSEMBLY

Models with Neutral

See Fig. 10

ITEM	PART NO.	DESCRIPTION	QTY.	FOOT	ITEM	PART NO.	DESCRIPTION	QTY.	FOOT
				NOTE					NOTE
1	233-0375	BEARING CUP	1		59	675-0326-V14	O-RING	1	
6	233-0489	BEARING CONE	1		60	688-0342	NUT, 1/2-20 UNJF-3B HIGH TENSILE HEX	1	
7	233-0492	BEARING CUP	1		61	688-0464	NUT, 3/8-24, THIN, PLATED, HEX, LOCK.	1	
8	233-0493	BEARING CONE	1		64	688-0738	NUT LOCK HEX 1 3/4-12	2	
16	235-0634	CAP, SHIFT CYLINDER	1		69	732-0467	SEAL, OIL	1	
26	237-0736-001	CARRIER, (180)	1		81	753-0232	PISTON, SHIFT	1	
29	265-0238	BOLT, 7/16-14 x 1-1/4 GR5 HH	10		82	756-0228	RING, REAR LOWER SHAFT w/NEUT	1	
33	265-0386	BOLT, 1/4-20 x 3/4 GR5 HH	4		83	756-0364	RING, SPACER, LWR, FRT	1	
37	339-0223	FELT WIPER	1		96	776-1397	SHAFT SUB-ASSY, (180)	1	
39	367-0286	FORK, SHIFT	1		97	776-0236-003	SHAFT, SHIFTER w/NEUTRAL, w/INDCTR GRV	1	
43	427-0523	GASKET, CARRIER	1		101	675-0012-V14	O-RING, PISTON	1	
50	432-1783	GEAR ASSY	1		115	927-0643	WASHER, SHIFT SHAFT, 3/8 I.D.	1	
51	432-0633	GEAR, SLIDING CLUTCH, SPUR	1		116	927-0722	WASHER, 1/2 SAE FLAT	1	
52	432-0634	GEAR, CLUTCH, FRONT DRIVE & PTO	1		120	927-0854	WASHER, THRUST LOWER GEAR	1	
56	675-0032-V14	O-RING, NEUTRAL CAP	1		121	927-0822	WASHER, NYLON PISTON STOP	2	
58	675-0316-V14	O-RING	1						

Footnotes:

1. See service manual.
2. Select one spacer ring. See service manual.

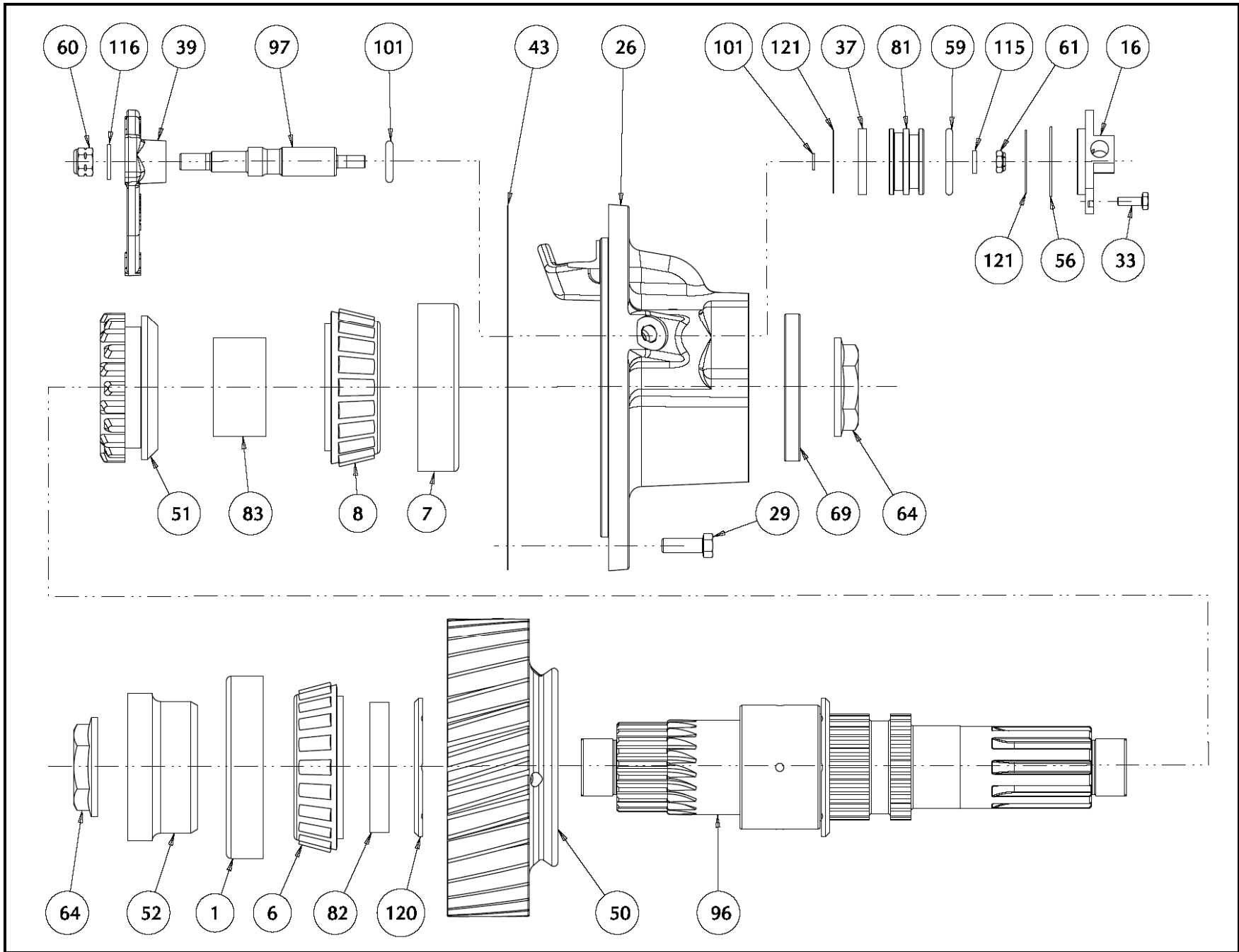

FIG. 10 - REAR OUTPUT SHAFT ASSEMBLY

Models with Neutral

Pro Gear and Transmission, Inc. | 906 West Gore St, Orlando, FL 32805

+1 (877) 776-4600 | +1 (407) 872-1901

www.progearandtransmission.com | www.pgtruckparts.com | parts@eprogear.com

TC-180 SINGLE-ACTING AIR SHIFT CYLINDER ASSEMBLY**All Models****See Fig. 11**

<u>ITEM</u>	<u>PART NO.</u>	<u>DESCRIPTION</u>	<u>QTY.</u>	<u>FOOT NOTE</u>
14	235-0352	CAP, SHIFT CYLINDER	1	
35	265-0768	BOLT, 7/16-20x1.5 LG GR8 DRILLED HH	2	
36	265-0769	BOLT, 1/4-20 x 3-3/4 GR5 HH	4	
37	339-0223	FELT WIPER	1	
38	367-0254	FORK, SHIFT	1	
57	675-0224-V14	O-RING	3	
59	675-0326-V14	O-RING	1	
61	688-0464	NUT, 3/8-24, THIN, PLATED, HEX, LOCK.	1	
70	736-0747	RING, STOP, PISTON	1	
76	742-0799	SHAFT, SHIFT	1	
80	746-0628	PIN DOWEL, .3125 x 1.25 STANDARD	1	
81	753-0232	PISTON, SHIFT	1	
89	758-0328	PLUG, WELCH 1 INCH	1	
99	777-0477	SPRING, HELICAL COMPRESSION	1	
101	675-0012-V14	O-RING, PISTON	1	
106	798-0245	SWITCH, INDICATOR LIGHT NO	1	
108	883-0482	TUBE, SHIFT CYL. ADAPTER	1	
109	883-0887-001	TUBE, SHIFT CYLINDER 2.75 LG.	1	
114	927-0427	WASHER, COPPER, SEALING	1	
115	927-0643	WASHER, SHIFT SHAFT, 3/8 I.D.	1	
122	947-0223	WIRE, LOCK, 18 GA.	1	

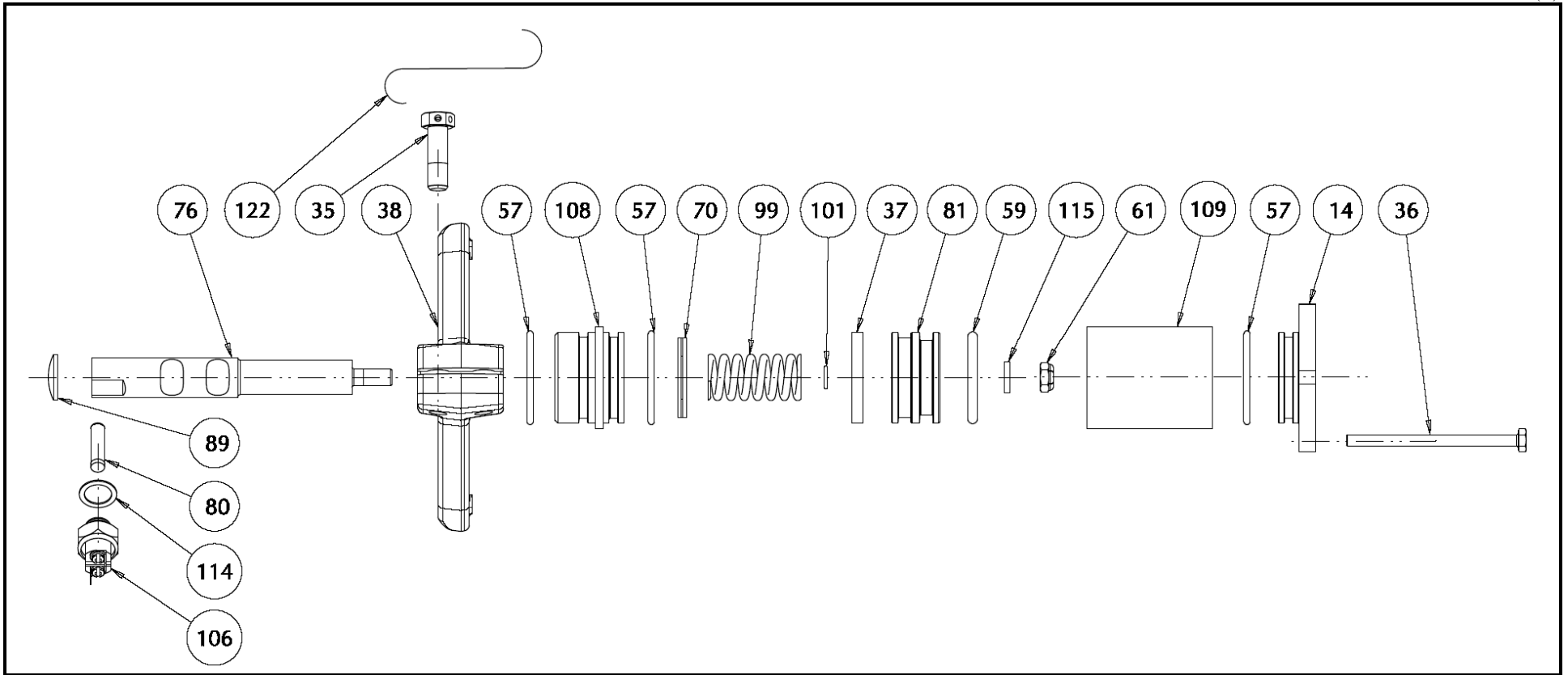

FIG. 11 - SINGLE-ACTING SHIFT CYLINDER ASSEMBLY
All Models

TC-180 LUBRICATION AND FITTINGS**Models without PTO Output****See Fig. 12**

<u>ITEM</u>	<u>PART NO.</u>	<u>DESCRIPTION</u>	<u>QTY.</u>	<u>FOOT NOTE</u>
1	273-0764	BRACKET, OIL FILTER MTG	1	
2	345-0267	FILTER, OIL	1	
3	345-0268	STRAINER, OIL	1	
4	357-0797	ADAPTER, 1/4 MNPT x #8 AN	1	
5	356-0365	NIPPLE, .75-16 UNF x 1.5 LONG	1	
7	366-0229	TEE, STL, #8 F SWIVEL x M JIC x M JIC	1	
8	357-0472	ELBOW,90 DEG, .50 FNPT x .50 MNPT	1	
9	357-0378	ELBOW, 90 DEG, 3/4 NPT X #12 AN	1	
10	357-0898	ELBOW, 90 DEG, .25 MNPT x #6 AN	1	
11	357-0293	ELBOW 90, 1/2 MNPT x #8M JIC 37	2	
12	469-0822-072	HOSE ASSY, #6 HOSE, 19.75in LONG	1	
13	469-0823-010	HOSE ASSY, #8, 11.25in LONG	1	
14	469-0823-001	HOSE ASSY, #8, 16.0in LONG	1	
15	469-0825-009	HOSE ASSY, #12 HOSE, 12.5in LG	1	
16	265-0323	BOLT, 5/16-18 x 1-1/4 GR5 HH	4	
17	824-0275	TEE, 3/4 FNPT x 3/4 FNPT x 3/4 MNPT	1	
18	927-0364	WASHER, 5/16 SAE, FLAT PLAIN	4	

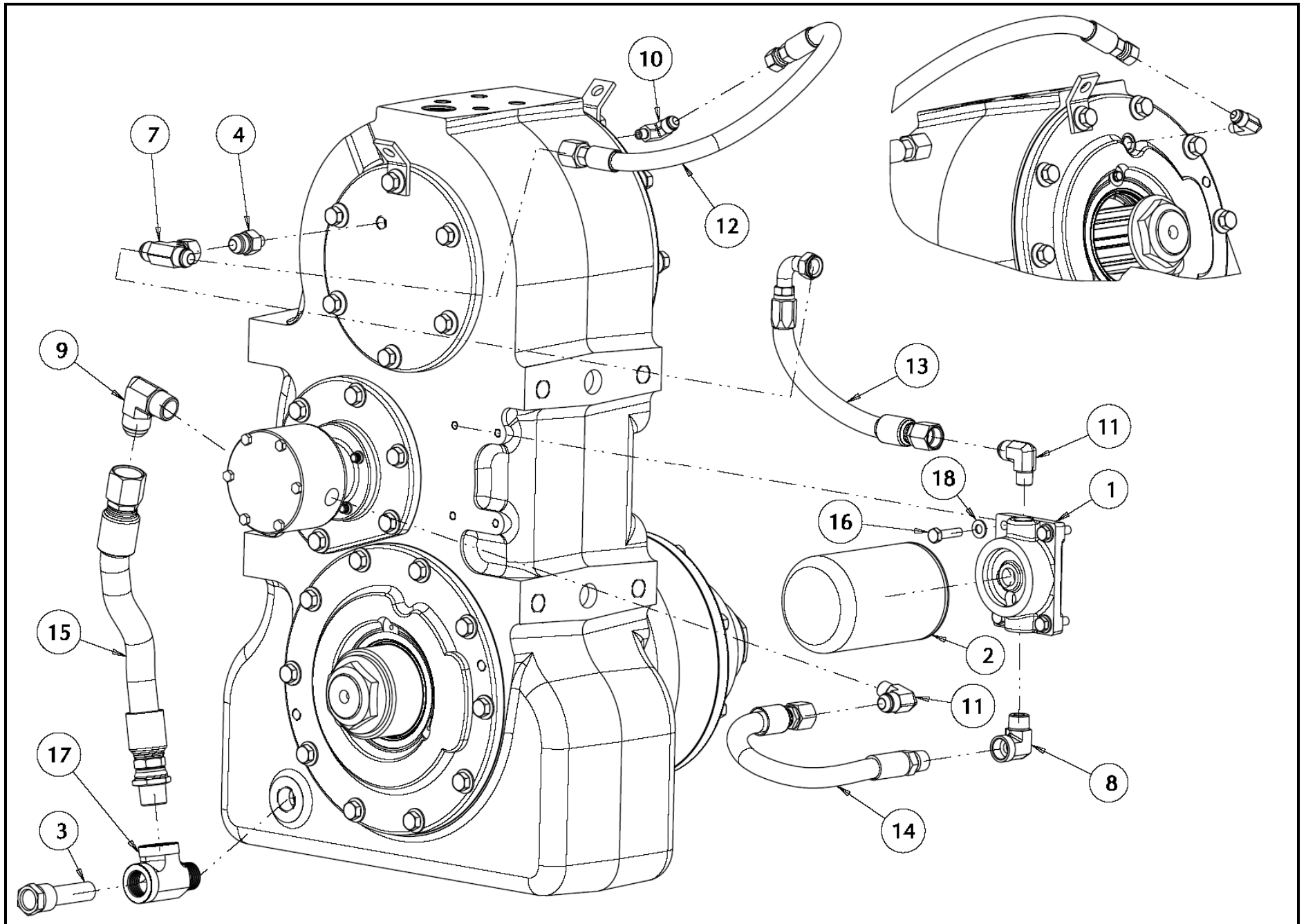

FIG. 12 - LUBRICATION AND FITTINGS

Models without PTO Output

Pro Gear and Transmission, Inc. | 906 West Gore St, Orlando, FL 32805

+1 (877) 776-4600 | +1 (407) 872-1901

www.progearandtransmission.com | www.pgtruckparts.com | parts@eprogear.com

TC-180 LUBRICATION AND FITTINGS
Models with PTO Output
See Fig. 13

<u>ITEM</u>	<u>PART NO.</u>	<u>DESCRIPTION</u>	<u>QTY.</u>	<u>FOOT NOTE</u>
1	273-0764	BRACKET, OIL FILTER MTG	1	
2	345-0267	FILTER, OIL	1	
3	345-0268	STRAINER, OIL	1	
4	357-0797	ADAPTER, 1/4 MNPT x #8 AN	1	
5	356-0365	NIPPLE, .75-16 UNF x 1.5 LONG	1	
6	357-0293	ELBOW 90, 1/2 MNPT x #8M JIC 37	2	
7	366-0229	TEE, STL, #8 F SWIVEL x M JIC x M JI	1	
8	357-0472	ELBOW,90 DEG, .50 FNPT x .50 MNPT	1	
9	357-0378	ELBOW, 90 DEG, 3/4 NPT X #12 AN	1	
10	357-0898	ELBOW, 90 DEG, .25 MNPT x #6 AN	1	
12	469-0822-077	HOSE ASSY, #6 HOSE, 16.3in LONG	1	
13	469-0823-017	HOSE ASSY, #8, 19.5in LONG	1	
14	469-0823-001	HOSE ASSY, #8, 16.0in LONG	1	
15	469-0825-009	HOSE ASSY, #12 HOSE, 12.5in LG	1	
16	265-0323	BOLT, 5/16-18 x 1-1/4 GR5 HH	4	
17	824-0275	TEE, 3/4 FNPT x 3/4 FNPT x 3/4 MNPT	1	
18	927-0364	WASHER, 5/16 SAE, FLAT PLAIN	4	

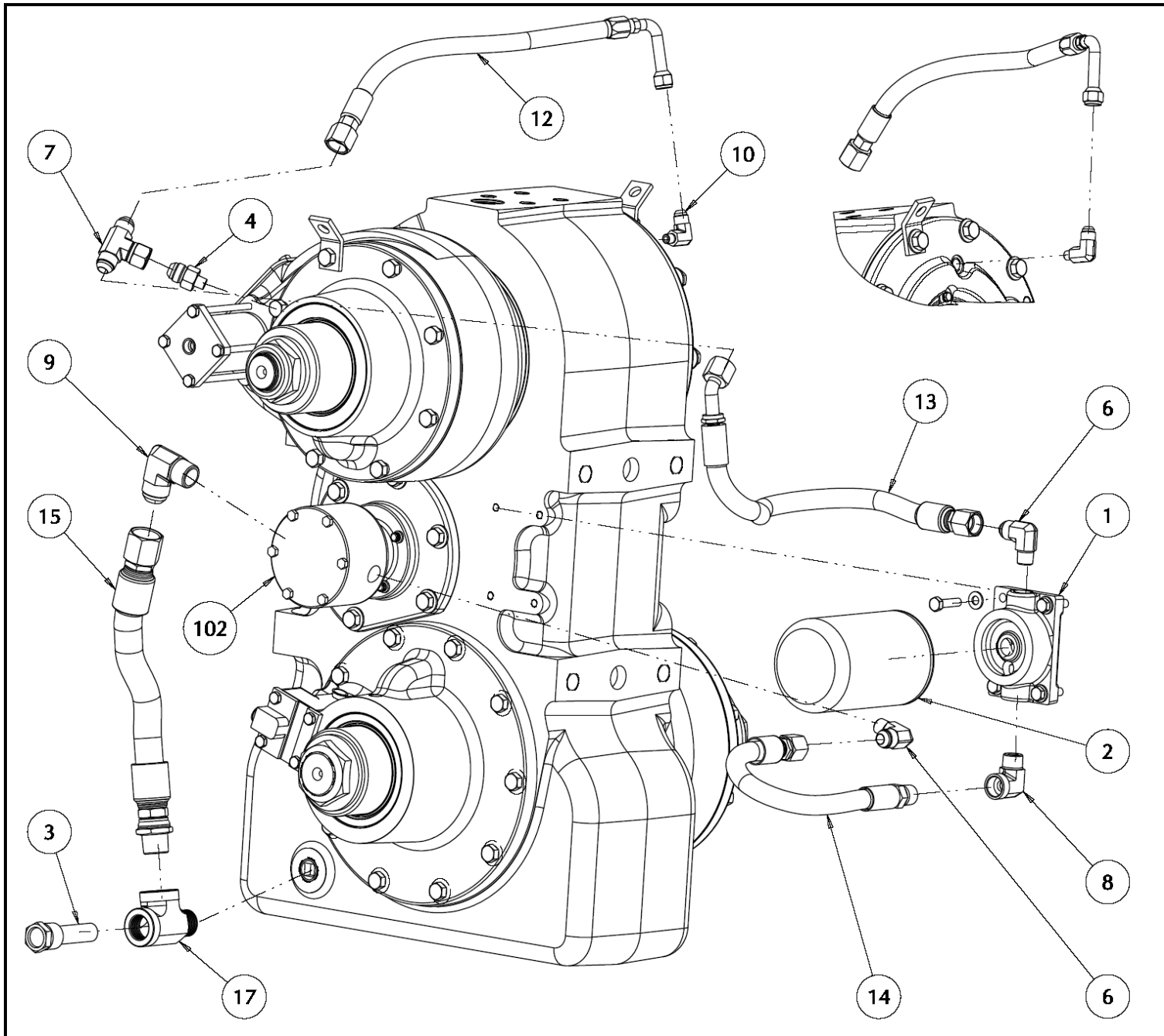

FIG. 13 - LUBRICATION AND FITTINGS

Models with PTO Output

Pro Gear and Transmission, Inc. | 906 West Gore St, Orlando, FL 32805

+1 (877) 776-4600 | +1 (407) 872-1901

www.progearandtransmission.com | www.pgtruckparts.com | parts@eprogear.com

TC-180 REMAINING PARTS**See Fig. 14**

<u>ITEM</u>	<u>PART NO.</u>	<u>DESCRIPTION</u>	<u>QTY.</u>	<u>FOOT NOTE</u>
54	478-0356	HOUSING, TRANSFER CASE, FINISHED,180	1	
55	626-0228	DATA PLATE, SERIAL NO.	1	
66	724-0276	SCREW, DRIVE, #6 x 5/16	2	
86	758-0229	PLUG, 3/4 NPT SQUARE COUNTERSUNK	2	
87	758-0293	PLUG, C.S., 1/2 NPT	2	
87A	758-0389	PLUG, W/ SIGHT GLASS AND REFLECTOR	1	
87B	758-0386	PLUG, W/O-RING, METAL, 3/4-16 THD.	1	
88	758-0274	PLUG, 3/4 NPT SQUARE SOCKET HEAD MAGNETI	1	

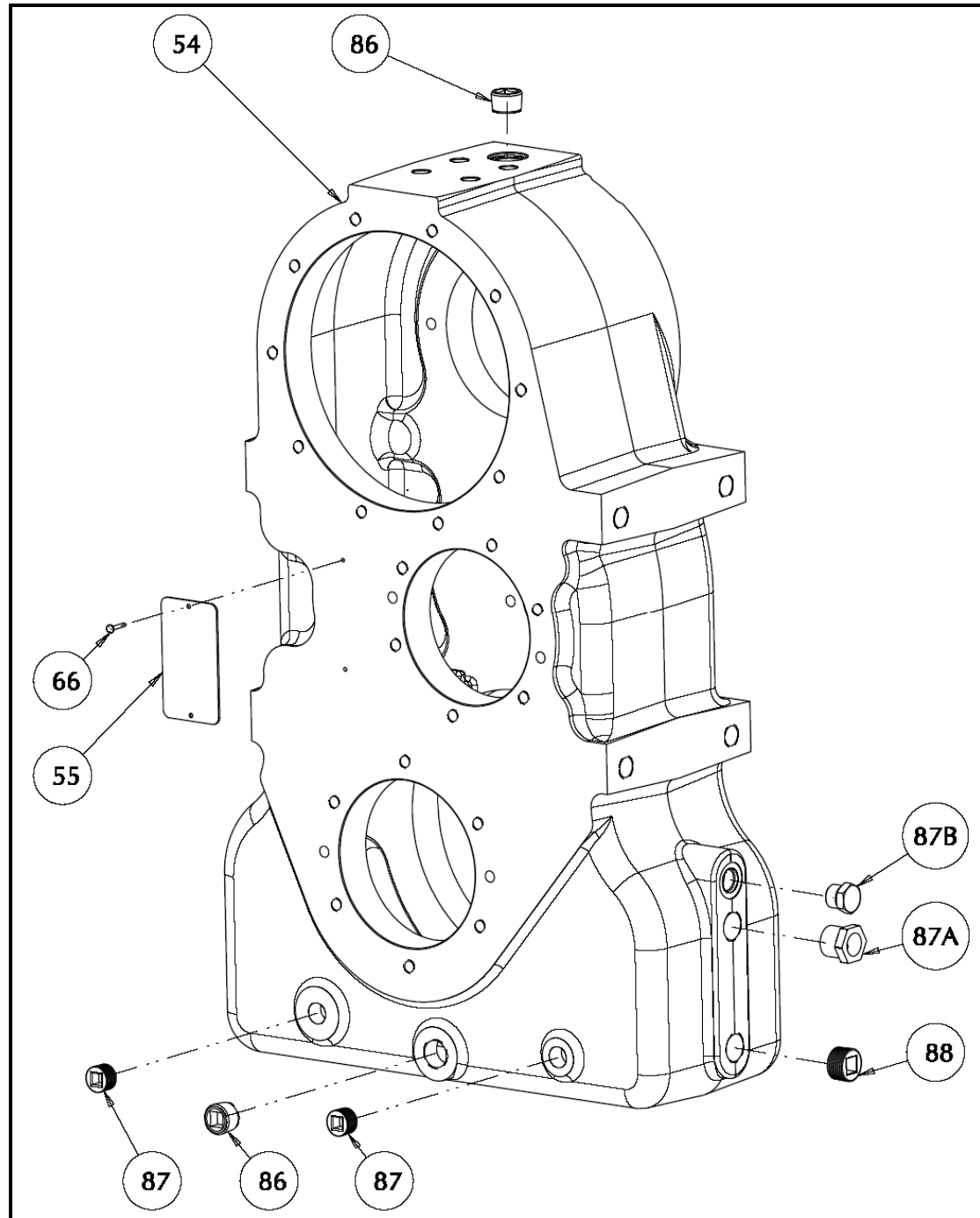

FIG. 14 - REMAINING PARTS

Pro Gear and Transmission, Inc. | 906 West Gore St, Orlando, FL 32805
+1 (877) 776-4600 | +1 (407) 872-1901
www.progearandtransmission.com | www.pgtruckparts.com | parts@eprogear.com